

# CorkSport Mazdaspeed Performance Camshafts

2007-2013 Mazdaspeed 3, 2006-2007 Mazdaspeed 6



Thank you for purchasing the CorkSport High Performance Camshafts. Developed with the latest design, manufacturing, casting technologies and CNC ground to CorkSport precision for the best performance for your Mazdaspeed. Please let us know your feedback by providing a review here: <https://corksport.com/mazdaspeed-3-camshafts.html>

## Pre-Installation Notes:



**Make sure your vehicle is completely cooled down** prior to starting installation. If you are going to work on your car within an hour or two of having driven it, use a fan to cool off the car.



**These instructions were written for reference only** and the use of a factory service manual is recommended. Please read these instructions thoroughly prior to starting installation.



**These installation instructions were written using a 2013 Mazdaspeed 3.** Other year Mazdaspeed 3 and Mazdaspeed 6 models will be similar.



**The install of the camshafts will require the replacement of two camshaft bolts, two camshaft friction washers, one fuel pump housing gasket and adjustment of the valve tappets.**



**The camshaft installation can average 5-8 hours and is rated a 5 out of 5 for difficulty. It will require some preparation and a clean workspace. If you have doubts in your skills do not attempt this installation. We strongly recommend professional installation.**



**We recommend changing your oil before installation. Clean oil gives the camshafts the best chance to ensure proper lobe break in and long life.**

## Materials and Time:



### General Info.

**Part #:** Gen-6-501-10  
**Time Est:** 5-8 hours  
**Wrench Rating:** 5/5



### Parts List

One (1) CorkSport Intake Camshaft  
One (1) CorkSport Exhaust Camshaft  
Two (2) M6x1.0x25mm Bolts

### Additional Parts List (not included)

Two (2) Camshaft Friction Washers (L3K9-12-429)  
Two (2) Camshaft Bolts (LF17-12-428)  
One (1) Fuel Pump Housing Gasket (L3K9-10-193)  
Tappets for valve adjustment



### Tooling List

1/4" Drive Ratchet  
3/8" Drive Ratchet  
1/2" Drive Ratchet  
1/2" Breaker Bar  
Impact Wrench  
Torque Wrench  
Jack and Jackstands  
Feeler Gauge  
Razor Blade

3mm Hex Socket  
8mm Socket  
10mm Socket  
12mm Socket  
17mm Socket  
21mm Socket  
12" Extension  
E8 Torx Socket  
T30 Torx Socket  
5/8" Spark Plug Socket

10mm Wrench  
12mm Wrench  
14mm Wrench  
17mm Wrench  
19mm Wrench  
21mm Wrench  
24mm Wrench  
Needle Nose Pliers  
Flat Head Screw Driver

OEM Engine Workshop Manual  
MZR Camshaft Alignment Tool  
MZR Crankshaft TDC Locater Pin  
Black/Grey Silicone Sealant  
Engine Assembly Lubricant  
Anti-Seize Lubricant  
Telescoping Magnet  
Telescoping Mirror



Need Help With Your Installation?  
Call (360) 260-CORK

## Order of Operations & Table of Contents



### Disassembly

Section 1: Access the Valve Cover

Section 2: Support the Car on Floor Jack/Jackstands or Lift

Section 3: Remove the Factory Camshafts

Pg. 1-4

Pg. 5

Pg. 6-10



### Installation

Section 4: Measure and Adjust Valve Lifter Clearance

Section 5: Install the CorkSport Camshafts

Section 6: Set the Camshaft Timing

Pg. 11-12

Pg. 13-16

Pg. 16-17



### Assembly

Section 7: Final Assembly

Pg. 18-21

## Detailed Instructions

 These instructions were made using a 2013 Mazdaspeed 3. Installation for earlier Mazdaspeed 3 and Mazdaspeed 6 will be similar.

### 1. Access the Valve Cover

- a) Remove the negative battery terminal and place the plastic cover back over the battery (green arrow in Figure 1a).



Figure 1a

- b) Remove the two 10mm bolts fastening the intercooler shroud to the intercooler. Push the shroud towards the firewall to unhook it and remove it from the vehicle (red circles in Figure 1b).

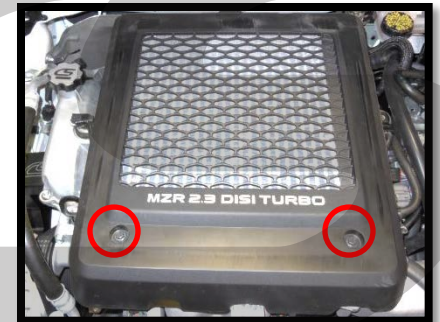



Figure 1b

 We recommend using plastic Ziploc bags and a sharpie to label all bolts and parts throughout the install.

- c) Remove the clamps for the throttle body and turbo boost tubes from the intercooler. Use a 10mm socket to loosen the clamps (green circles in Figure 1c).

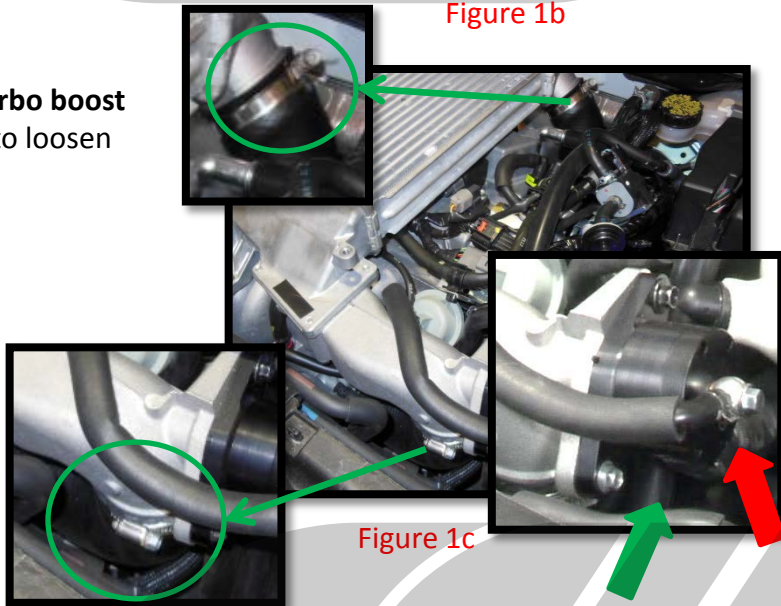

Figure 1c

- d) Detach the bypass valve (BPV) from the intake. Remove the vacuum signal hose (red arrow), and the large BPV to the intake hose by compressing the clamp with pliers (green arrow in Figure 1c). Leave the bypass valve attached to the intercooler pipe.

- e) Remove the three (3) 12mm nuts fastening the intercooler to the top of the engine and remove the intercooler from the vehicle by pulling upward (Figure 1d).



Figure 1d

## 1. Access the Valve Cover (continued)

f) **Remove the intake.** Loosen the hose clamp connecting the intake elbow to the turbo inlet pipe with a 10mm socket wrench (red circle in Figure 1e).

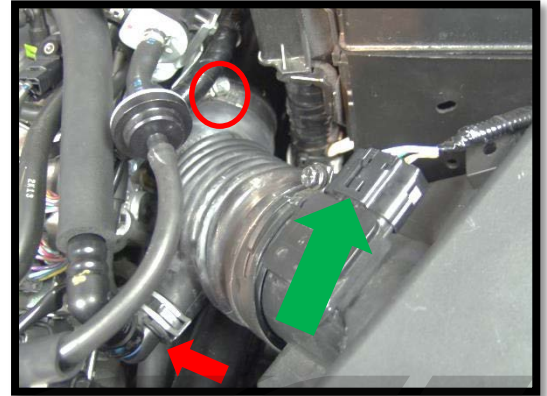

Figure 1e

g) **Remove the breather pipe from the valve cover** (red arrow in Figure 1e) and unplug the MAF sensor (green arrow in Figure 1e).

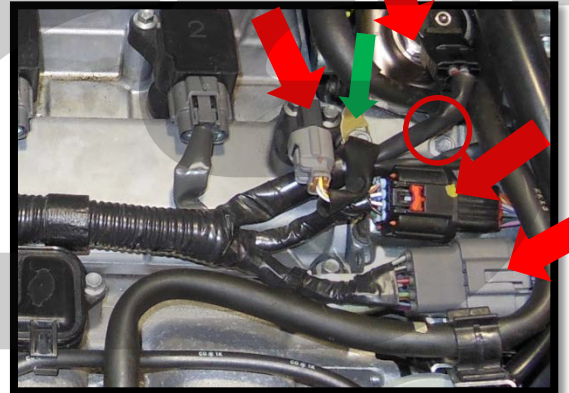

Figure 1f

h) **Pull the intake out of the engine bay.**

i) **Unplug the five (5) engine wiring harness connectors** (red arrows in Figure 1f and 1g).



Do NOT unbolt the coil pack grounding wire (green arrow in Figure 1f)

j) **Unbolt the wiring harness bracket** (red circles in Figure 1f and 1g) with an 8mm socket wrench and lift it away from the motor.

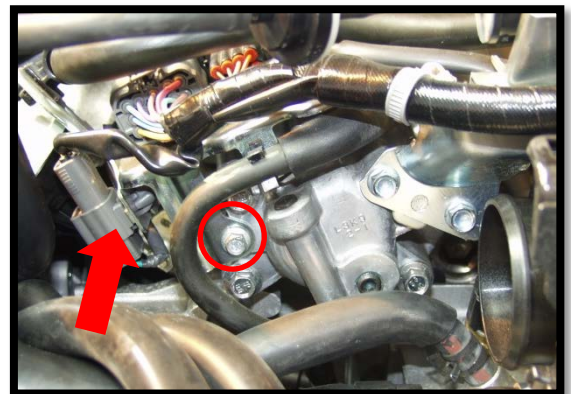

Figure 1g

k) **Remove the evap. solenoid and brake booster hoses** (red arrows in Figure 1h). Disconnect the spring clamps and pull off the hose. Push the two hoses out of the way toward the radiator.

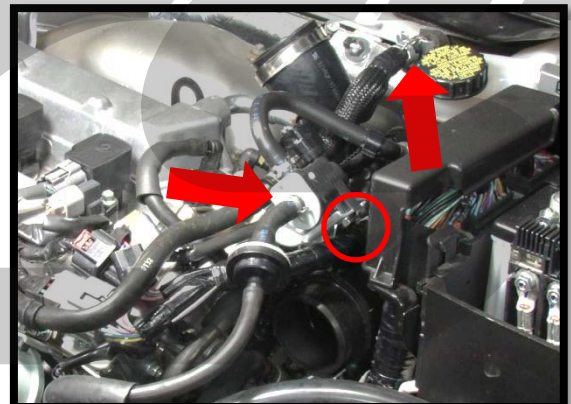

Figure 1h

l) **Unbolt the evap. solenoid from the bracket** with a 10mm wrench (red circle in Figure 1h). Push it out of the way toward the firewall.

## 1. Access the Valve Cover (continued)

m) Remove the turbo inlet pipe bracket by removing the three (3) 10mm fasteners with a socket wrench (red circles in Figure 1i).

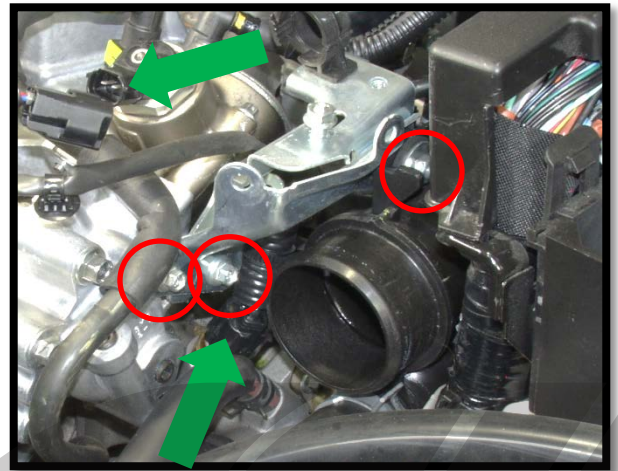

Figure 1i

n) Unplug the coolant temperature sensor and fuel pump electrical connectors (green arrows in Figure 1i).

o) Unplug the four (4) spark plug coil connectors (red arrows) the camshaft position sensor & oil control valve (green arrows) and pull the wiring harness away from the motor towards the radiator (Figure 1j).

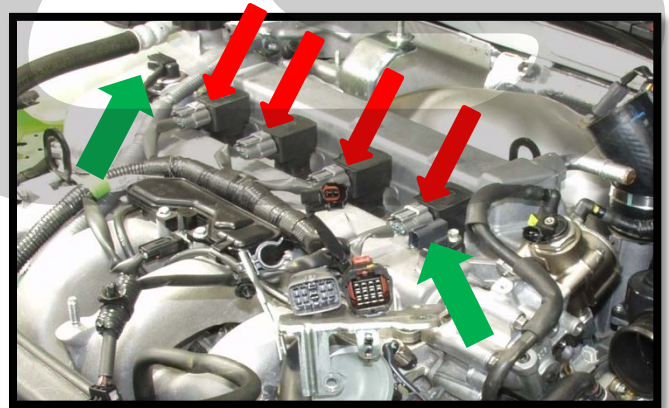

Figure 1j

p) Unbolt the bracket holding the grey harness to the intercooler bracket with a 10mm wrench (green arrow in Figure 1k).

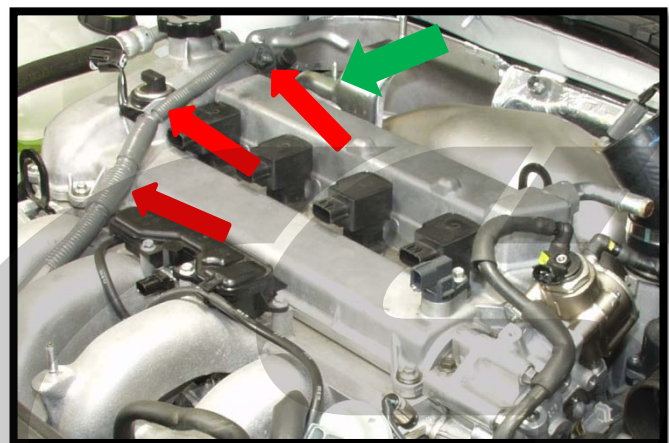

Figure 1k

q) Disconnect the grey wiring harness from the engine and pull it aside over the oil filler neck (red arrows in Figure 1k).

## 1. Access the Valve Cover (continued)

r) **Remove the high pressure fuel pump.** Use the open end of a 19mm wrench to loosen the hard line connection (green arrow in Figure 1l).

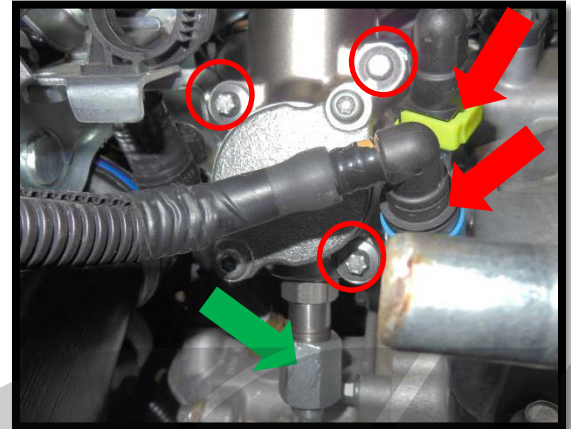

Figure 1l

s) **Use a flat head screw driver** to carefully pry out the blue and yellow clips and pull the fuel lines off the pump (red arrows in Figure 1l).

t) **Use an E8 reverse Torx** to remove the three (3) Torx screws from the pump (red circles in Figure 1l) and remove the fuel pump from the car.

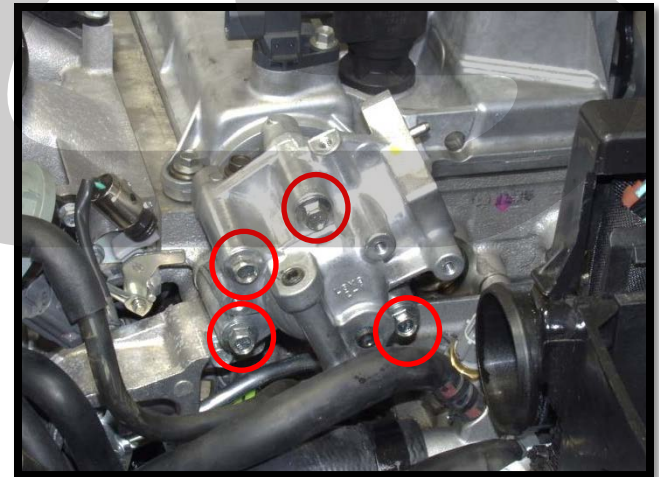

Figure 1m



Take care not to drop the lifter located inside the housing upon removal.

u) **Remove the fuel pump lifter housing.** Use a 10mm socket wrench to remove the four (4) screws (red circles in Figure 1m) and pull the lifter housing off the engine.

v) **Remove the four spark plug coils** (red arrows in Figure 1j) with an 8mm socket wrench. Shown removed in Figure 1n.

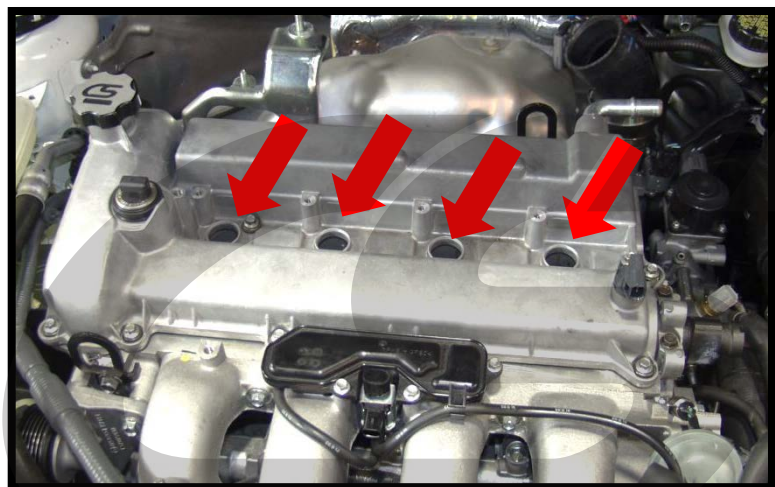

Figure 1n

w) **Remove all four (4) spark plugs** with a spark plug socket and extension (red arrows in Figure 1n).

## 2. Support the Car on Floor Jack/Jackstands or Lift

- a) Use a floor jack and jackstands to gain access to the underside of the vehicle.



Always refer to the floor jack and jack stand manufacturers instructions as well as the factory owners manual for your vehicle to determine jacking points and support points. Alternately, use an automotive lift to gain access to the underside of the vehicle. Redundant support mechanisms are recommended.

- b) Remove the passenger's side front wheel with a 21mm lug wrench.



Push Clip

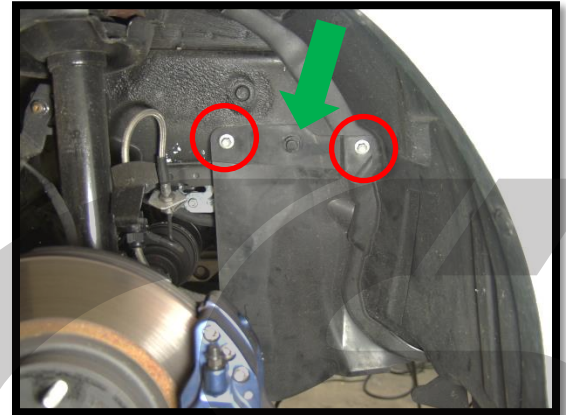

Figure 2a

- c) Remove the passenger's side fender well splashguard. Use a 10mm socket wrench to remove the two (2) screws (red circles) and a flat blade screw driver to remove the clip (green arrow in Figure 2a).

## 3. Remove the Factory Camshafts

- a) Use an 8mm socket wrench to remove the fourteen (14) 8mm bolts fastening the valve cover to the head (valve cover removed exposing camshafts in Figure 3a).

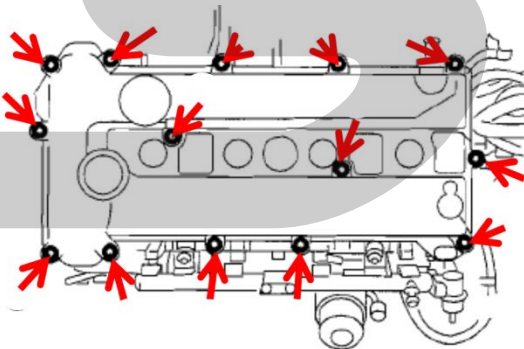

Figure 3a

- b) Remove the serpentine belt. Use a long 14mm wrench to turn the belt tensioner clock wise (red arrow in Figure 3b). Loosen the belt and remove it from the car.

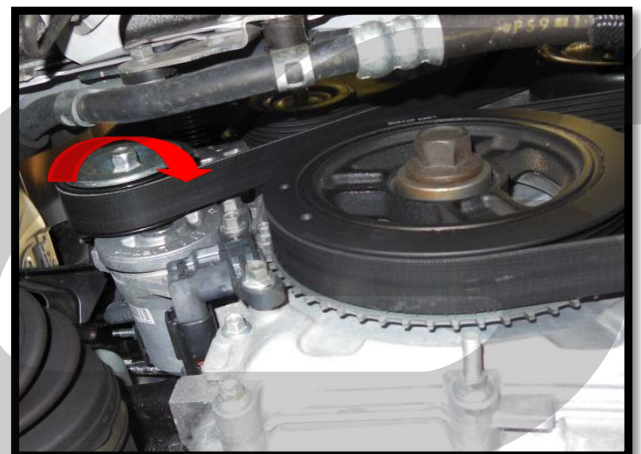

Figure 3b



## 3. Remove the Factory Camshafts (continued)

- c) Turn the crankshaft with the 21mm bolt clock wise, to approximately 15° Before Top Dead Center (Figure 3c).



BTDC is located before the holes on the crankshaft pulley line up, and when the #1 camshaft lobes are pointed toward each other as shown in Figure 3d.

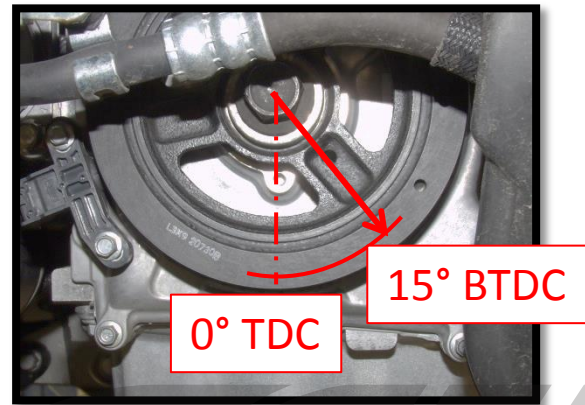

Figure 3c

- d) Locate the crankshaft blind plug (red circle in Figure 3e). Remove it with a 10mm wrench.

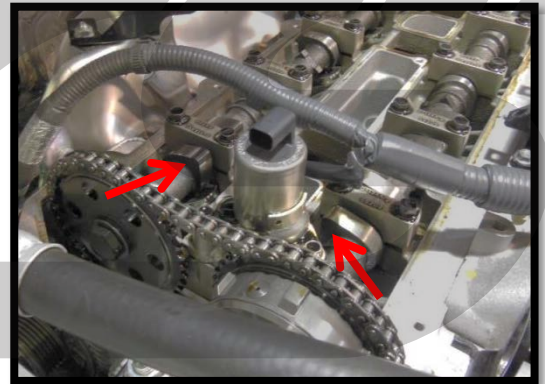

Figure 3d

(#1 cam lobes pointed toward each other)

- e) Screw the TDC locator pin into the cylinder block all the way by hand (Figure 3f).

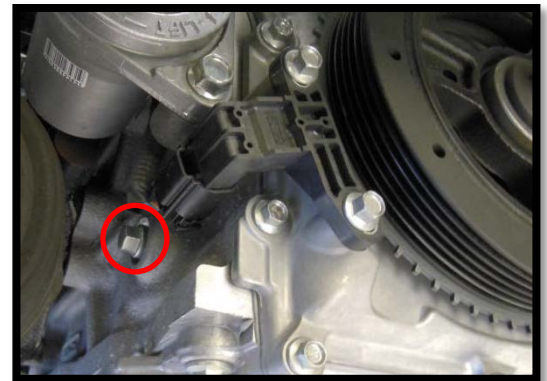
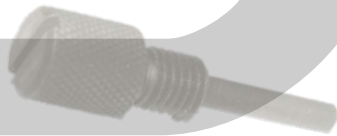

Figure 3e

- f) Continue turning the crankshaft clock-wise to Top Dead Center until the crankshaft hits the locator pin and stops. The hole in the crankshaft pulley will line up with the threaded hole in the timing cover (shown as 0° TDC in Figure 3g).

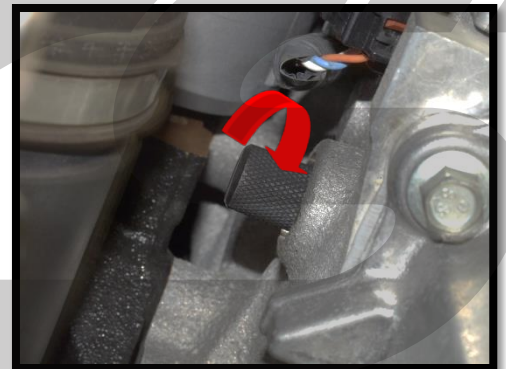

Figure 3f

**3. Remove the Factory Camshafts (continued)**

- g) Thread a 25mm long M6x1.0 bolt through the hole in the crankshaft pulley (green arrow) into the threaded hole in the timing cover. Gently tighten it, locking the crankshaft at 0° TDC (Figure 3g).

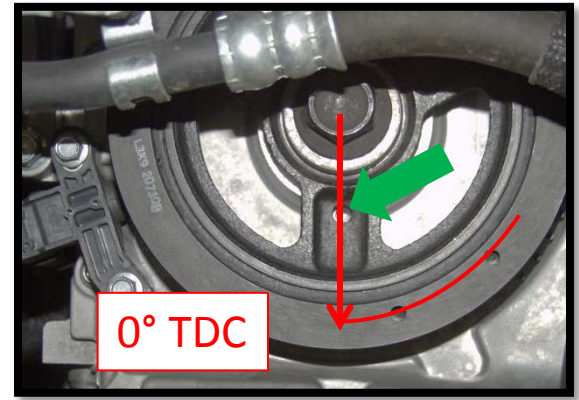

Figure 3g

- h) Looking down from the top of the engine, locate the timing chain rail blind plug in the side of the timing cover (red circle in Figure 3h). Remove the plug with a 10mm wrench.

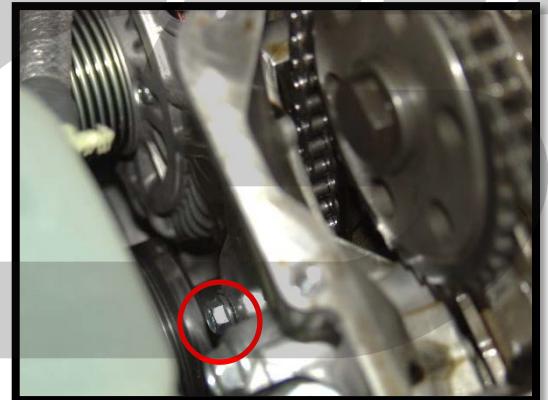
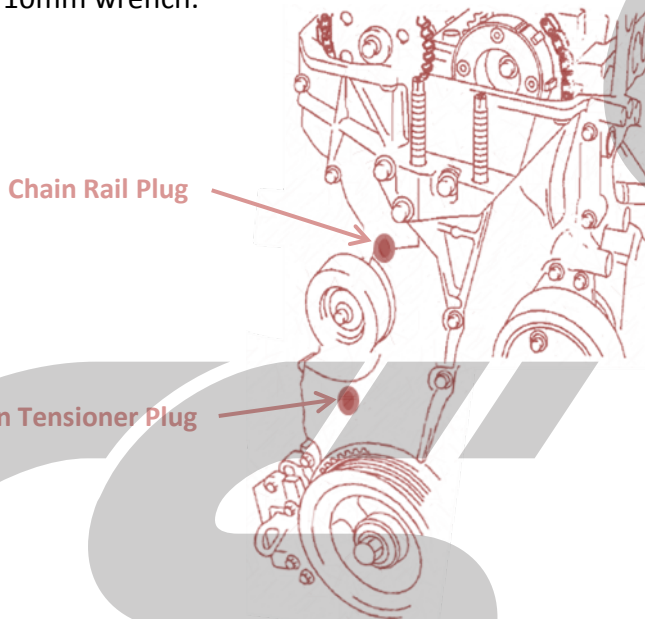

Figure 3h

- i) Use another 25mm long M6x1.0 bolt to thread into the timing chain rail plug hole. Do not thread it all the way in, just enough to keep it in place (red circle in Figure 3i).



Figure 3i

- j) Use a 1/4" ratchet with a T30 Torx socket to remove the timing chain tensioner plug (red circle in Figure 3j).



Figure 3j

## 3. Remove the Factory Camshafts (continued)

- k) Place the open end of a 23mm wrench onto the hex portion of the exhaust cam (as shown in [Figure 3k](#)). Hold onto the wrench with your right hand.
- l) While holding a 3mm hex socket in your left hand, reach down between the engine and frame rail and insert the hex into the tensioner blind plug hole ([Figure 3l](#)).



Figure 3k

- m) Push the tab inside of the hole back toward the firewall ([Figure 3m](#)).



Pushing this tab will unlock the tensioner ratcheting mechanism. This requires a good amount of force. Removal of the PMM may help with this process.

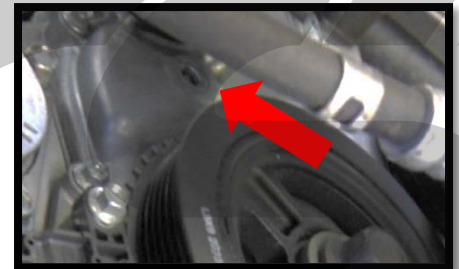
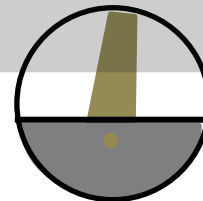

Figure 3l

- n) While holding the tensioner tab with your left hand, rotate the camshaft clock-wise with the wrench. (2 people highly recommend for this)



This action will compress the timing chain tensioner. When done correctly it will create a small amount of slop in the timing chain between the two camshaft sprockets.



Locked

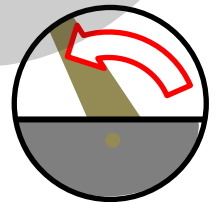

Un-Locked

Figure 3m

- o) Continue to hold the camshaft and thread the bolt you placed in the chain rail hole in [step 3i](#) all the way into the timing chain cover ([Figure 3n](#)).



This bolt will keep the timing chain rail from springing back into a tensioned state.

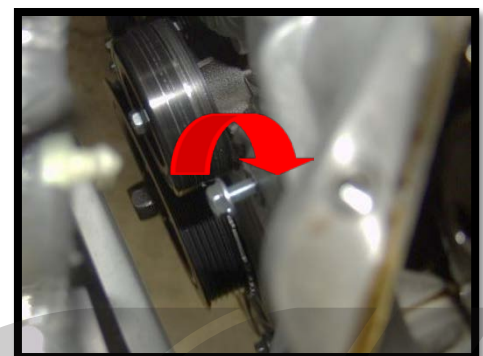

Figure 3n

- p) This process of locking the chain tensioner rail should result in a small amount of slop in the timing chain. To check if the rail has been locked properly, turn the exhaust camshaft slightly in both directions and verify there is some slop in the chain ([Figure 3p](#)).

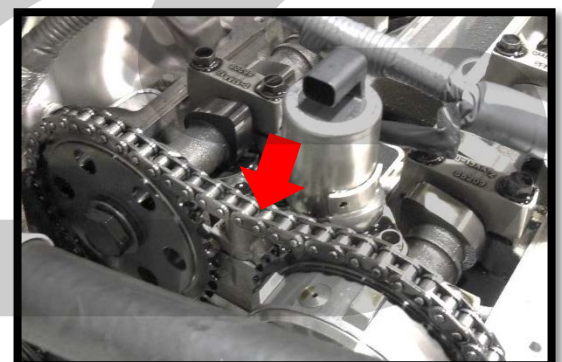

Figure 3p

## 3. Remove the Factory Camshafts (continued)

- q) Remove the M6 bolt threaded through the crankshaft pulley un-locking it from the timing cover (red circle in Figure 3q).

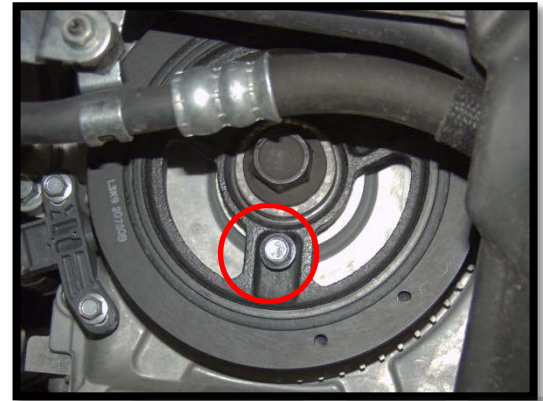

Figure 3q

- r) Turn the crankshaft back to approximately 15° BTDC using a 21mm wrench on the crankshaft pulley bolt (Figure 3r).



By turning the crankshaft backward, you are gaining clearance between the piston tops and valves which will be necessary measuring shim adjustments. Failure to do so may result in internal engine damage!

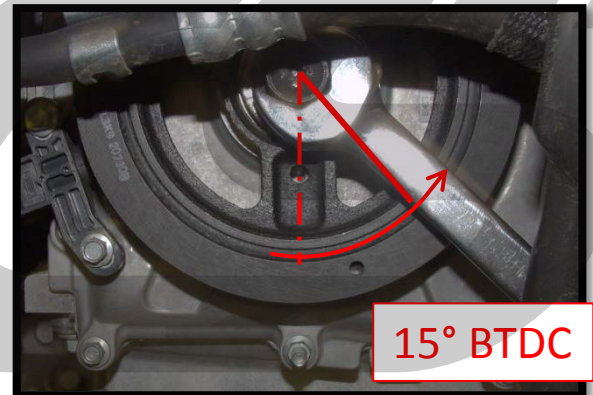

Figure 3r

- s) Loosen the exhaust timing chain pulley bolt (red arrow in Figure 3s). Hold the camshaft in place with a 23mm wrench and loosen the bolt with a 21mm wrench.



Do NOT drop the washer located between the pulley and the camshaft! Use a magnet to hold onto the washer while removing the pulley (red arrow in Figure 3t).

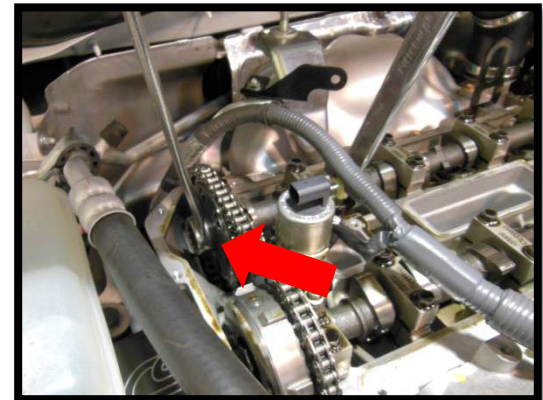

Figure 3s

- t) Unthread the pulley bolt the rest of the way by hand and remove the exhaust timing chain pulley from the motor.

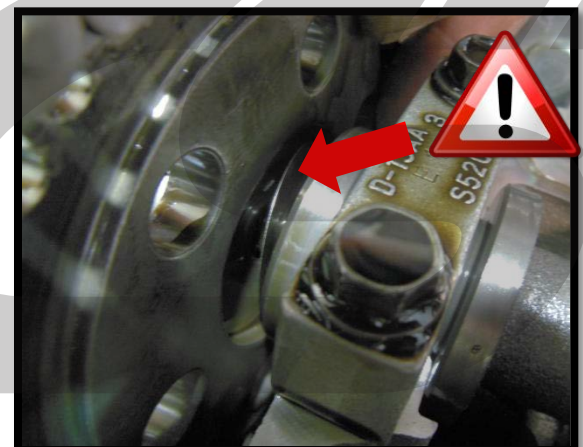
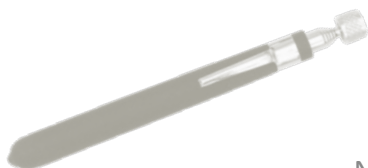

Figure 3t

Need Help With Your Installation?  
Call (360) 260-CORK

## 3. Remove the Factory Camshafts (continued)

- u) **Remove the oil control valve.** Remove the 8mm bolt (red circle) with a socket wrench, and pull the valve upward (Figure 3u).
- v) **Remove the camshaft bearing caps in order according to Figure 3v** (1,1,2,2,3,3,4,4,5,5,6,6). Loosen each cap in small increments going through the sequence 2 or 3 times per camshaft.
- w) **Lay out all the caps and camshafts on a clean surface in the exact order and orientation they were removed (Figure 3w).**
- x) **Remove the camshafts from the engine.**

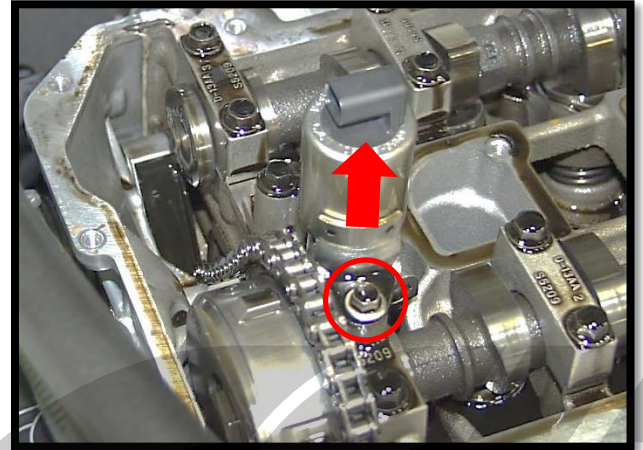

Figure 3u

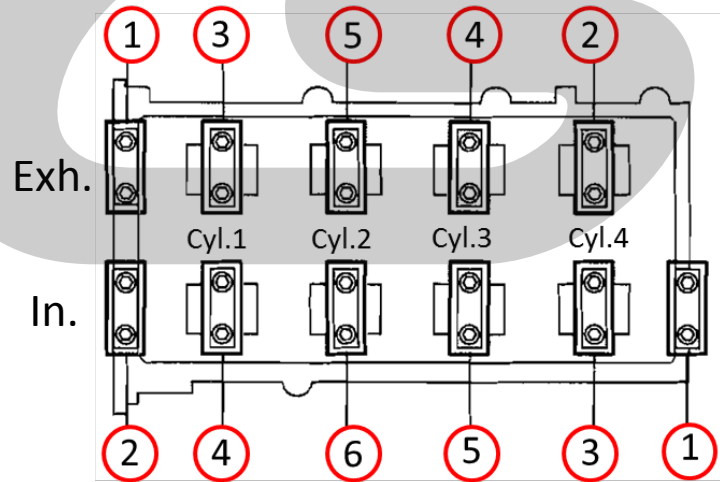

Figure 3v



Do not loosen the camshaft out of order. Failure to do so may cause the camshafts to bind resulting in internal engine damage.



Use your magnet or a screwdriver to keep the chain from falling down inside of the motor.

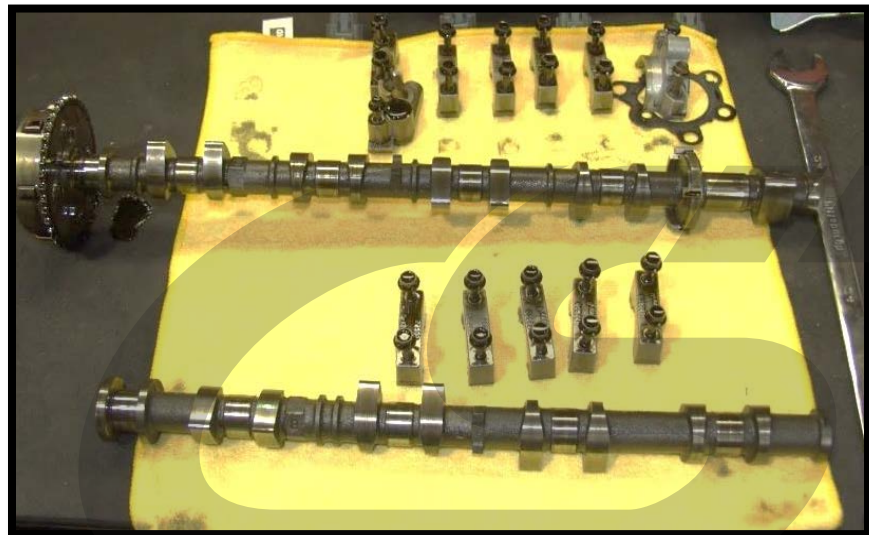

Figure 3w

Need Help With Your Installation?  
Call (360) 260-CORK

## 4. Measure and Adjust Valve Lifter Clearance



To measure the correct gap between the valve tappets and new camshafts, you will need to temporarily install both CorkSport intake and exhaust camshafts.

- a) **Liberaly apply engine assembly lubricant to all machined bearing surfaces on the camshafts and place them into the head (Figure 4a).**

- b) **Replace the bearing caps and tighten down the camshafts in the order shown in Figure 5g.**



Follow the tightening sequence and torque specs on page 14.

- c) **Use a feeler gauge to measure the clearance between the tappets and camshaft lobes (as pictured in Figure 4b).** Record the measured values in the columns on the next page.



Please reference OEM Engine Workshop Manual L3 with TC for exact process to measure valve clearance. Section 01-10-28

**Standard Valve Clearance**  
 Ex: 0.27-0.33 mm (0.011-0.012 in)  
 In: 0.22-0.28 mm (0.0087-0.011 in)

- d) **Remove the camshafts** using the same procedure in step 3v.

- e) **Use a small clean magnet to remove the tappets that are out of clearance** according to the specifications listed above and on the next page (Figure 4c).



Make sure to note numbers on bottom side of tappet and place in order with rest of camshaft parts for reference for re-assembly.

exhaust

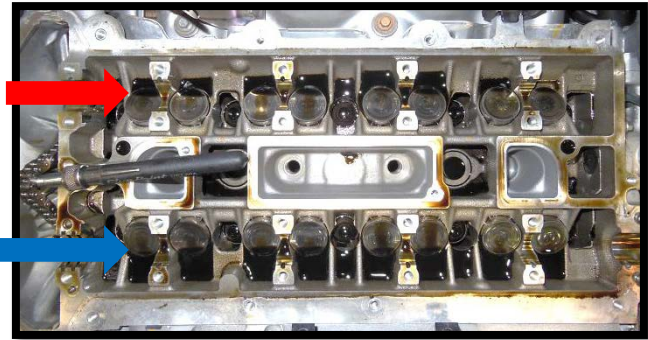

Intake

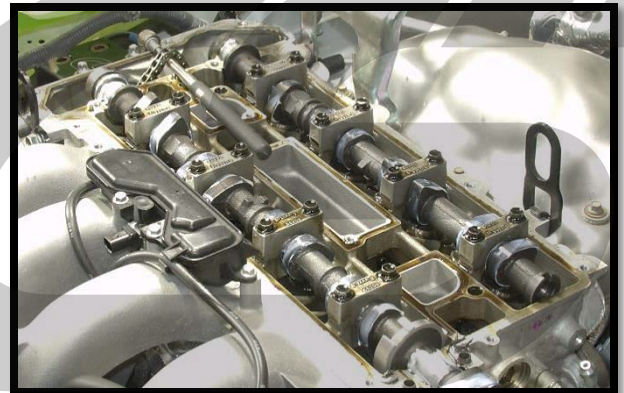

Figure 4a



Figure 4b

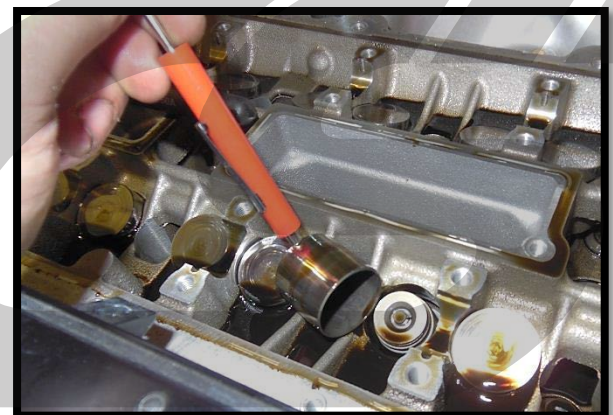

Figure 4c

Need Help With Your Installation?  
 Call (360) 260-CORK

### 4. Measure and Adjust Valve Lifter Clearance (continued)

Use this worksheet to record Tappet numbers located on the underside of the tappets and your measured valve clearances. Visit our Tappet number matrix and enter your numbers to get the correct thickness and part numbers for your installation.

Removed tappet thickness #



Measured valve clearance

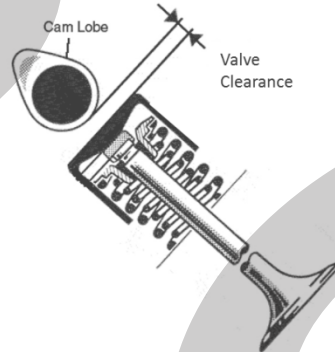

Tappet needed.

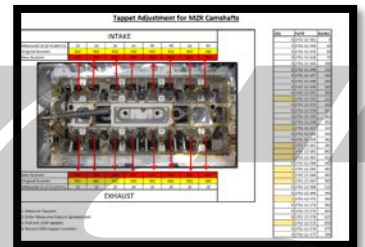

**Standard Valve Clearance**

EX: (0.27-0.33 mm)

EX: (0.011-0.012 in)

Exhaust Camshaft

	Cyl.1	Cyl.2	Cyl.3	Cyl.4
Removed tappet #				
Measured valve clearance				

Intake Camshaft

**Standard Valve Clearance**

IN: (0.22-0.28 mm)

IN: (0.0087-0.011 in)

	Cyl.1	Cyl.2	Cyl.3	Cyl.4
Removed tappet #				
Measured valve clearance				

Enter your recorded numbers into the CorkSport Tappet Guide spreadsheet to obtain correct tappet part numbers.

[CorkSport Tappet Guide](#)

Tappets required

	Cyl.1	Cyl.2	Cyl.3	Cyl.4
Exhaust				
Intake				

## 5. Install the CorkSport Camshafts

- a) Remove the adjustable cam gear from the factory intake camshaft. Place the camshaft on a bench. Use the 23mm wrench on the hexagonal portions of the camshaft to keep it from twisting and break the bolt loose with a 21mm socket (Figure 5a).

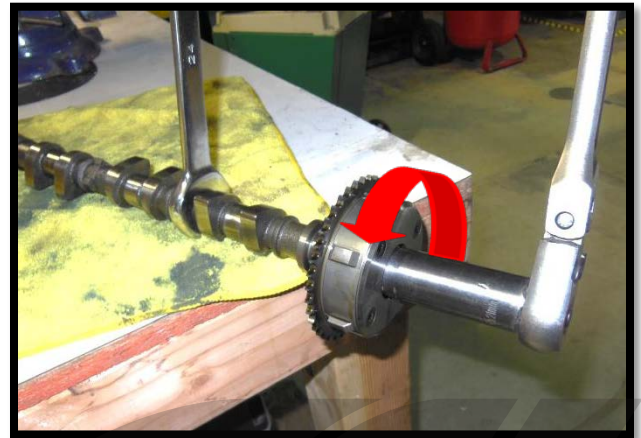

Figure 5a

- Take notice of the metal washer (Figure 5b). Replace with part# L3K9-12-429

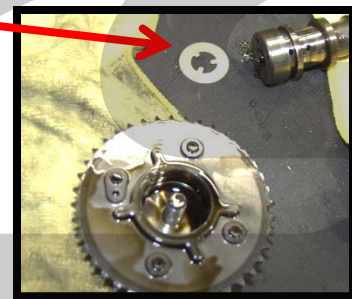



Figure 5b

- b) Install the adjustable cam gear onto the CorkSport intake camshaft. Replace the 21mm bolt (part # LF17-12-428) and place the new friction washer between the sprocket and camshaft.
  - a) Tighten to **94-101nm (70-75 ft-lb)**

- c) Thoroughly lubricate both camshafts journals and lobes with engine assembly lube and place them into the head with the #1 lobes (red arrows) facing upward and towards each other (Figure 5c).



Figure 5c

 Use a high quality assembly lube, failure to do so can cause camshaft and/or engine failure.

- d) Place the camshaft bearing caps back into the head in the same order they were removed. Do not tighten at this time.

- The bearing caps are stamped (red arrows) by their locations and face the driver's side.
  - I3= Cyl. 3 intake
  - E3= Cyl. 3 exhaust(Figure 5d)

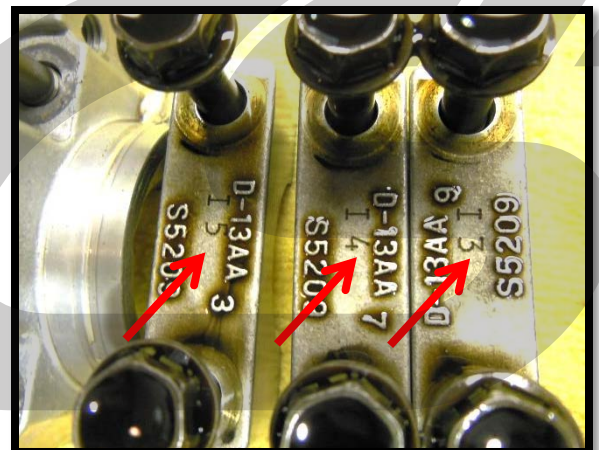

Figure 5d

Need Help With Your Installation?  
Call (360) 260-CORK



**5. Install the CorkSport Camshafts (continued)**

e) Place a small bead of silicone sealant (red lines in Figure 5e) onto the head mating surface of the #6 intake bearing cap. Finger tighten the 10mm bolts.

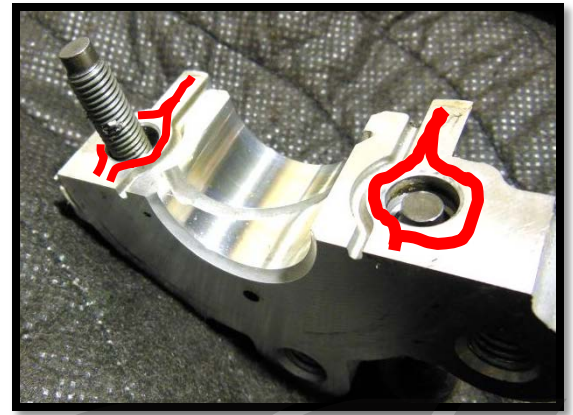

Figure 5e

f) Gently tighten down the intake camshaft cap bolts in 2 or 3 passes. Follow the tightening sequence shown in Figure 5g. Do not torque down the bolts at this time.



Slightly rotating the camshafts back and forth will help keep them from binding during the tightening sequence.



Figure 5f

g) Repeat the process for tightening the exhaust camshaft.

h) Torque the cap bolts fully in two passes in the tightening sequence (Figure 5g).

Camshaft bearing cap tightening sequence

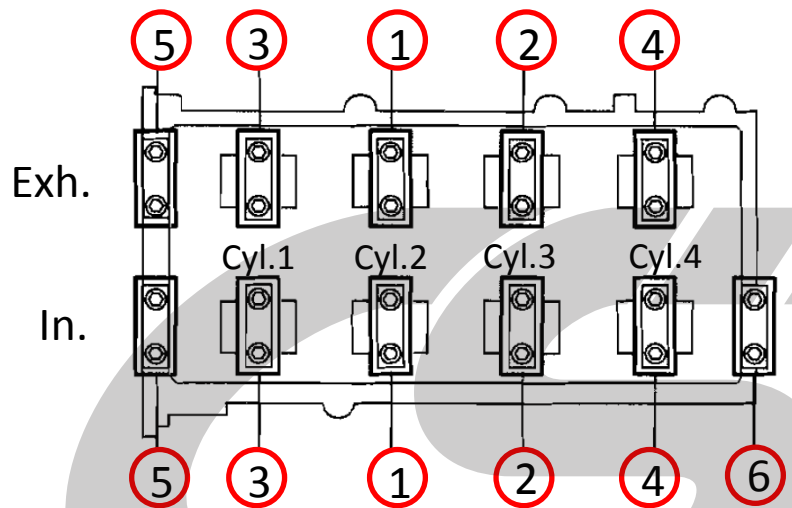

Figure 5g

Cap bolt torquing sequence

1<sup>st</sup> pass: 5.0-9.0 Nm (45-79 in/lb)

2<sup>nd</sup> pass: 14.0-17.5 Nm (10.4-12.5 ft/lb)



Over torquing the cap bolts will cause excessive wear on the camshaft bearing surfaces causing engine failure. Follow the sequence above. Refer to the service manual for additional information.

**5. Install the CorkSport Camshafts (continued)**

- h) Place the camshaft locking tool into the slots machined into the ends of the camshafts (as shown in **Figure 5h**).

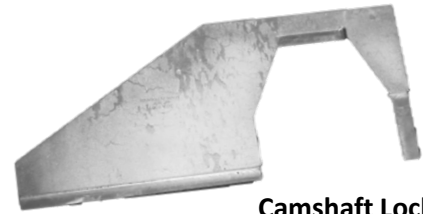

Camshaft Locking Tool



You may need to rock the camshafts slightly with the 23mm wrench to get the tool to lock into place.



Figure 5h

- i) Rotate the Crankshaft clock wise, back to TDC (**Figure 5i**).

- j) Replace the M6 locking bolt through the crank sprocket (**green arrow**) and tighten it into the timing cover.

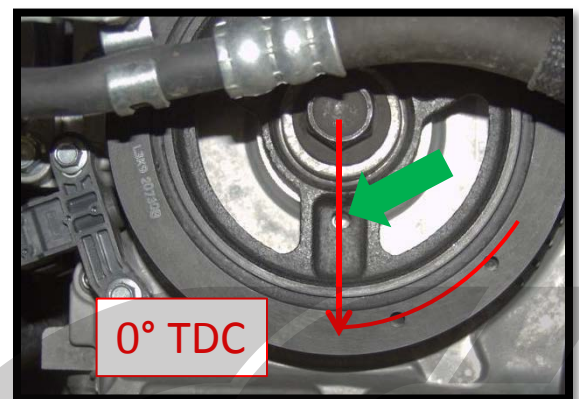

Figure 5i

## 5. Install the CorkSport Camshafts (continued)

- h) **Place the exhaust timing sprocket onto the exhaust camshaft.** Place the bolt through the flat side of the sprocket and the washer (red arrow) into the recessed side. Loop it through the timing chain and place it onto the camshaft. Hand thread the bolt into the camshaft and do not tighten at this time (Figure 5j).



Do NOT drop the washer located between the pulley and the camshaft!

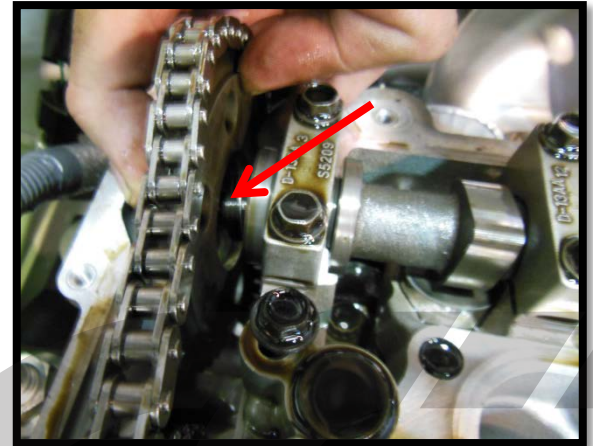

Figure 5j

## 6. Set the Camshaft Timing

- a) **Take notice of the slot in the bolt recess of the intake camshaft adjuster (red arrow).** Make sure the slot in the inner part of the adjuster lines up with the outer, if not, turn the outer toothed portion of the sprocket by hand until the two slots line up (Figure 6a).
- b) **Remove the timing chain locking bolt you installed in step 3i (red circle in Figure 6b).**



This will allow the chain tensioner to rebound, tightening the chain.



Figure 6a



Figure 6b

**6. Set the Camshaft Timing (continued)**

c) **Tighten the exhaust timing chain sprocket.** Use a 24mm wrench to hold the hex portion of the camshaft and 21mm wrench to lightly tighten the bolt (**Figure 6c**). Then use a torque wrench to fully tighten to **94-101nm (70-75 ft-lb)**.



Figure 6c

d) **Remove the crankshaft pulley locking bolt** (**red circle** in **Figure 6d**).

e) **Remove the TDC Locator pin** installed in step 3e (**green circle** in **Figure 6d**).

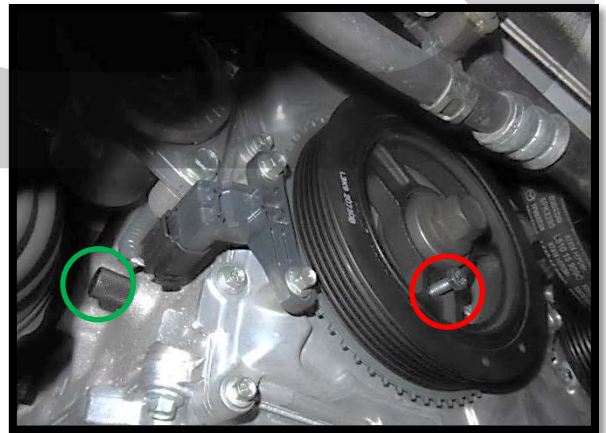

Figure 6d

f) **Remove the camshaft locking tool** (**Figure 6e**).

g) **Using a 21mm socket, rotate the crankshaft clockwise two (2) full rotations.**



The engine should turn smoothly.

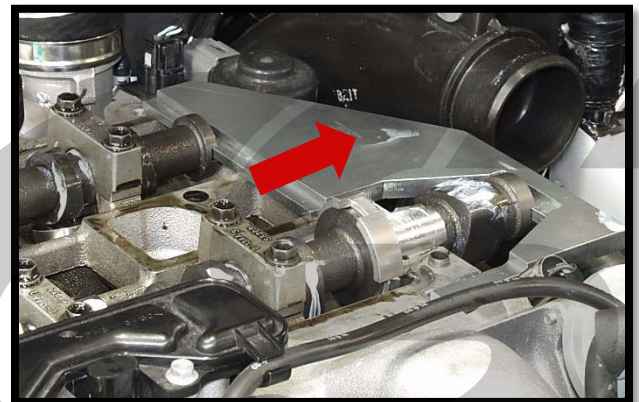

Figure 6e

## 7. Final Assembly

- a) Replace the TDC locator plug (red circle in Figure 7a).
- b) Replace the chain tensioner and rail blind plugs removed in steps 3h-3j.



Figure 7a

- f) Replace the oil control valve (Figure 7b). Torque to 8-11.5 nm (71-102 in-lbs).

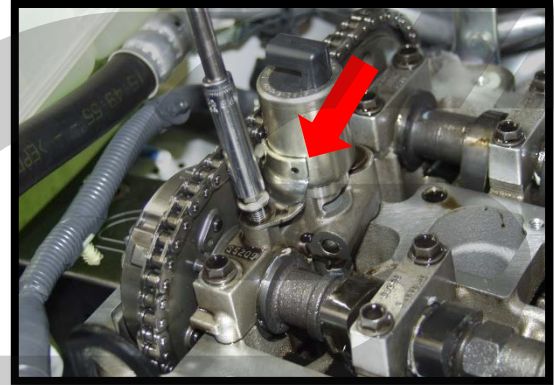

Figure 7b

- c) Clean the valve cover sealing surface. Remove any old silicone carefully with a fresh razor blade.

- e) Apply silicone sealant to the cracks where the timing cover mates to the head, and where the #6 intake bearing cap meets the head (green arrows in Figure 7c).

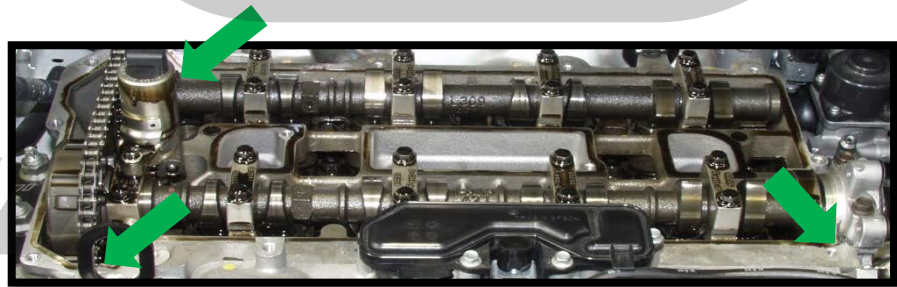

Figure 7c



Failure to seal the valve cover properly will result in oil leak/leaks.

- f) Replace the valve cover (Figure 7d). Tighten down the fourteen (14) bolts starting from the center bolts and working your way outward to 8-11.5 nm (71-92 in-lbs).
- g) Apply Anti-Seize compound to the spark plugs and install them. Torque to 10-14nm (8-10 ft-lbs)
- h) Replace the four (4) spark plug coils (Figure 7d).

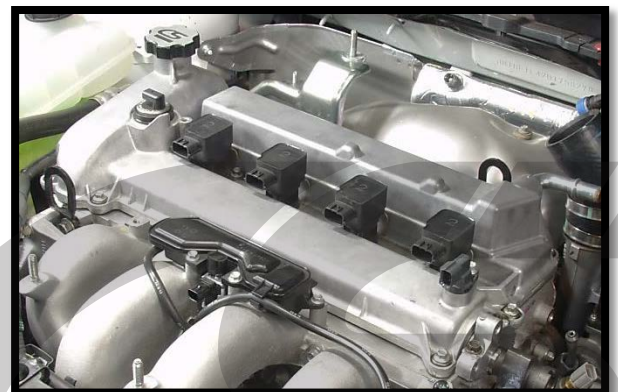



Figure 7d

**7. Final Assembly (continued)**

- f) **Replace the fuel pump tappet housing.** Use a new gasket and tighten the four (4) bolts to **8-10.5 nm (71-92 in-lbs)** (Figure 7e).

 Replace gasket with part# L3K9-10-193

- g) **Lubricate the fuel pump tappet with engine assembly lube** and place it flat side down inside the tappet housing (Figure 7f).

 **Installation of the lifter incorrectly will result in the fuel pump and camshaft failure.**

- h) **Push the high pressure fuel pump into the tappet housing** and fasten it down with the three (3) E8 Torx screws (Figure 7g).

 You will be pushing the pump against the spring. Take care not to bind the pump housing, and tighten the screws by small increments in an even pattern.

 **Do not force the pump into place by tightening the screws. Serious engine damage could occur.**

- i) **Tighten the hard high pressure fuel line with a 19mm wrench** (Figure 7g).

- j) **Pull the engine wiring harness back into place** and plug in the coolant temp sensor (green arrow in Figure 7h).

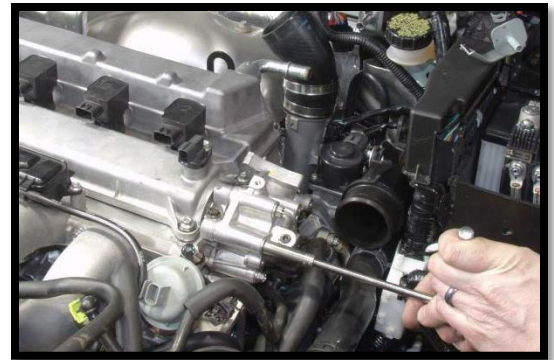

Figure 7e

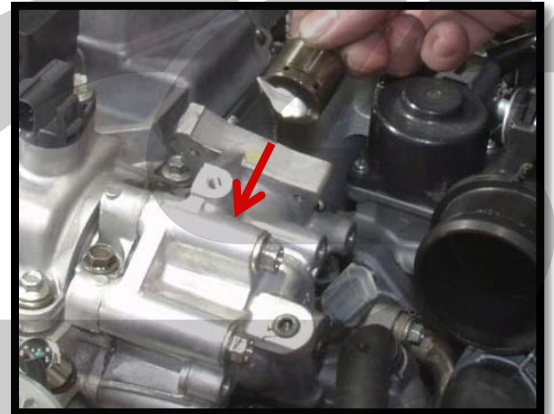

Figure 7f



Figure 7g

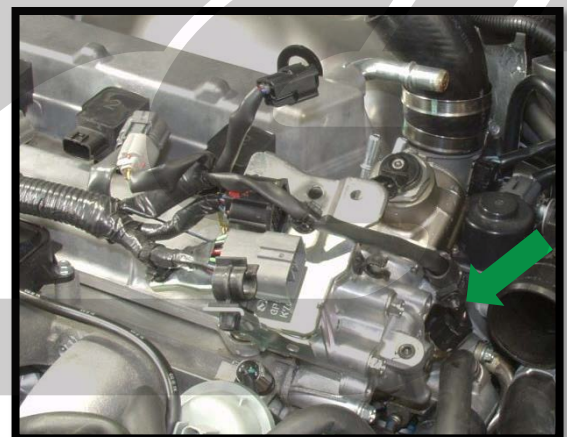

Figure 7h

## 7. Final Assembly (continued)

- k) Replace the intake bracket (red arrow) and fasten it with the nut and two (2) bolts removed in step 1m (Figure 7i).
- l) Replace the wiring harness bracket (green arrow) and fasten it in place with the two (2) 8mm bolts removed in step 1j (Figure 7i).
- m) Re-connect the high pressure fuel pump electrical connector (blue arrow in Figure 7i).
- n) Re-connect the coil, cam sensors, and main wiring harness plugs (red arrows in Figure 7j).
- o) Replace the two (2) flexible fuel lines by simply pushing them back onto the fuel pump (yellow arrow in Figure 7k).
- p) Replace the evap. solenoid, vacuum and brake booster lines (red circle in Figure 7k).
- q) Reconnect the breather pipe removed in step 1g.
- r) Replace the intake and intercooler removed in steps 1b to 1h (Figure 7l).

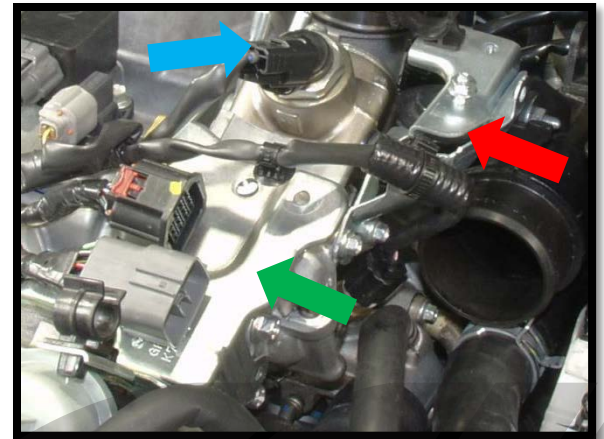

Figure 7i

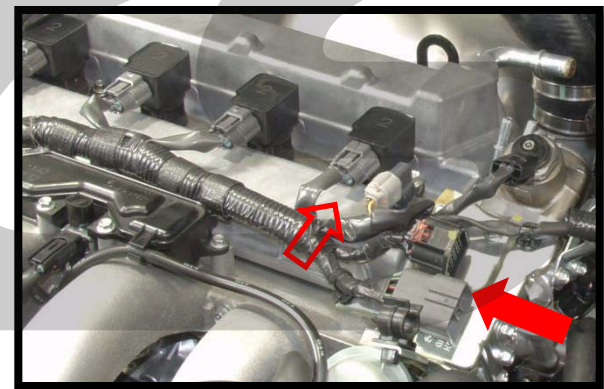

Figure 7j



Figure 7k



Figure 7l

### 7. Final Assembly (continued)

- s) **Install the serpentine belt.** Guide it through the pulleys leaving the water pump last (marked WP in **Figure 7m**). Turn the tensioner (T) clock wise with a 14mm wrench and slip the belt over the water pump pulley.
- t) **Replace the inner fender splash shield** that was removed in (**step 2c**).
- u) **Replace the wheel** and torque down the lug nuts to your wheel manufacturers specifications.
- v) **Re-connect the negative battery terminal.**

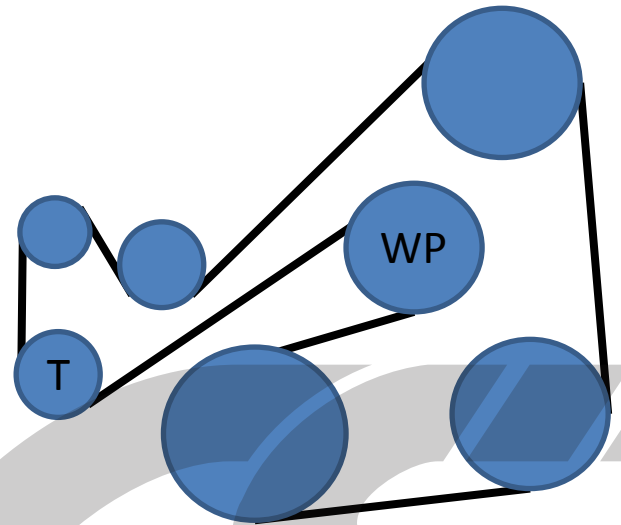

Figure 7m

### 8. Break-In the CorkSport Camshafts

- a) **Start the engine and run 2000 rpm for 10 minutes.**
- b) **Re-check valve clearance** (refer to section 4) after 1000 mi or if excessive noise is noticed during break in period.
- c) **Change your oil after 1500 miles of camshaft installation.**



**This completes the installation of your CorkSport High Performance Camshafts. Check for oil leaking at the valve cover and the fuel pump tappet housing after breaking in the camshafts. When no leaks are found and no check engine light (CEL) is present, test drive the car and listen for excessive tappet noise. Drive the car normally for 1000 miles and recheck for tappet noise and oil leaks.**



## What's Next:



### CorkSport VTA BPV

The CorkSport Binary VTA BPV provides features and performance to suit stock cars and on up to big turbo high power setups. The CorkSport Binary VTA BPV holds 50psi, responds in 50 milli-sec, and won't stall your car every shift. All this comes in a compact design with nozzle adjustability to allow for easy installation in even the most cramped engine bay or with custom piping.

### CorkSport High Pressure Fuel Line

The CorkSport High Pressure Fuel Line designed for the MZR DISI. The line is designed to replace the OEM line which can be prone to failure at the brazed connection at the rail. The custom machined fittings designed to work with the OEM rail and fuel pump outlet for a bolt in design. The lines are rated to 3000psi and have been burst tested to 14000psi.



### CorkSport DISI MZR Fuel Injector Seals

CorkSport DISI MZR Fuel Injector Seals for the 2007-2013 Mazdaspeed 3 & 2006-2007 Mazdaspeed 6. Constructed from beryllium copper; the CorkSport fuel injector seals will lock in every PSI of boost so that every bit of your hard earned horsepower keeps you moving forward.

